



**INVITATION TO BID FOR
THE PURCHASE OF GOODS**

Deadfront Padmounted Switchgear

Bid No.: 26-138-G

Closing Date: Tuesday, July 28, 2026

Time: 2:00 PM, PT

Description: *Deadfront Padmounted Switchgear 15 KV*

Purchasing Contact: Kristin Kokkeler

(541) 685-7107

kristin.kokkeler@eweb.org

Pre-bid Conference: NO

This is a **COMPETITIVE SEALED PROCUREMENT**. ELECTRONIC PROPOSALS SUBMITTED VIA THE OREGONBUYS BID SITE ARE REQUIRED. Emailed submittals will not be accepted.

To ensure your submission is received prior to the closing date and time, it is recommended that you begin the submittal process on the OregonBuys website at least 72-hours prior to the closing date and time listed above.

To ensure your submission is received prior to the closing date and time, it is recommended that your response is submitted electronically on the OregonBuys website, or if in person, via a Commercial Carrier such as UPS or FedEx, or in person by appointment with the Purchasing Contact.

SINGLE POINT OF CONTACT: *There will be only one point of contact for the entire Invitation to Bid process. The contact point is the EWEB Purchasing Office, and the contact person is the Purchasing Contact listed above. Any questions or issues that may arise regarding the specifications, the bidding process, and/or the award process shall be directed to the Purchasing Contact listed above. EWEB's official response to any questions or requests will be in writing through the Addendum process.*

FOR MORE INFORMATION please refer to Part 1 "Instructions to Bidders".

TABLE OF CONTENTS

Section	Description
	Legal Advertisement
1	Instructions to Bidders
2	Sustainability
3	Technical Requirements / Scope of Work
4	Bid Form

Exhibits

1	Sample Contract
2	EWEB Specification ES5-5.1100 Rev. 1

LEGAL ADVERTISEMENT

ITB #26-138-G
Deadfront Padmounted Switchgear

The Eugene Water & Electric Board (EWEB) requests bids from companies interested in providing Deadfront Padmounted Switchgear 15 KV..

Bids shall be uploaded to the OregonBuys website before, 2:00 PM PT, Tuesday, July 28, 2026. Bids will not be accepted after this hour and date.

ITB documents may be downloaded from the State of Oregon's bid site ("Oregon Buys"): <https://oregonbuys.gov/bs/> (On OregonBuys home page, search for bid # **26-138-G**. For navigation help, please call 1-855-800-5046.)

All bids shall be submitted as set forth in Section 1 - Instructions to Bidders. EWEB is not responsible for bids submitted in any manner, format or to any delivery point other than as required by the Solicitation Document.

No bid may be withdrawn after the hour set for the opening thereof until the elapse of thirty (30) days from the date and time set for opening.

EWEB reserves the right to waive any or all informalities and irregularities (EWEB Rule 3-0470) and may cancel the Invitation to Bid or reject any or all bids pursuant to EWEB Rule 3-0640.

Date: July 7, 2026

Kristin Kokkeler
Purchasing Contact

1. INSTRUCTIONS TO BIDDERS

All bids and contracts are subject to the provisions and requirements of the Oregon Revised Statutes ORS 279A and 279B and EWEB Public Contracting Rules Divisions 1,2, 3 and 6.

INFORMATION OF RECORD

The official source of information for this project until the Intent to Award is posted is located at the State of Oregon's bid site, located at: <https://oregonbuys.gov/bs/>. IT IS THE SOLE RESPONSIBILITY OF THE BIDDER TO CHECK THE WEBSITE ON A TIMELY BASIS.

BID PREPARATION

1.1 BID FORMAT

Bids shall be typewritten or prepared in ink and shall be submitted on the form provided in the Invitation to Bid. No oral, telegraphic, telephone or faxed bids shall be accepted.

1.2 CONFORMANCE TO BID REQUIREMENTS

Bids shall conform to the requirements of the Invitation to Bid. All necessary attachments (recycled products certification, non-collusion certification, descriptive literature, etc.) shall be submitted with the bid and in the required format. Bid prices shall be for the unit indicated on the bid. Failure to comply with all requirements may result in bid rejection.

1.3 PRODUCT IDENTIFICATION

Bidders shall clearly identify all products bid. Brand name and model or number shall be shown. EWEB reserves the right to reject any bid when the product information submitted with the bid is incomplete.

1.4 USE OF BRAND OR TRADE NAMES

Any brand or trade names used by EWEB in bid specifications are for the purpose of describing and establishing the standard of quality, performance and characteristics desired and are not intended to limit or restrict competition. Bidders may submit bids for substantially equivalent products to those designated unless the Invitation to Bid provides that a specific brand is necessary because of compatibility requirements, etc. All such brand substitutions shall be at the sole discretion of EWEB.

1.5 ALTERNATE BRAND OR RESERVED

Bids will be accepted for any brand offered if the product meets or exceeds the quality or performance levels of the brand specified. Bidders offering alternate brands are requested to include the following information with their bids:

1. A signed statement explaining the difference between the specified brand and/or model and the product offered; and
2. Two sets of detailed specifications to determine whether the product offered meets bid specifications

1.6 PROTEST OF SPECIFICATIONS /REQUIREMENTS

A Bidder who believes that the procurement process is contrary to law, or that the solicitation is unnecessarily restrictive in that specifications limit competition arbitrarily, without reasonably promoting the fulfillment of the procurement needs of EWEB, or that the solicitation document is legally flawed in that it contains terms or conditions that are contrary to law, or that the solicitation improperly specifies a brand name as defined in ORS 279B.200, may submit a protest via email to kristin.kokkeler@eweb.org. Insert the following in the subject header:

ITB SPECIFICATION PROTEST, ITB #26-138-G

To be considered, protests shall be received **no less than 5 business days before close (EW-3-0700(2))**.

Protest of specifications shall include the reason for protest, any and all evidence and documented

factual information that supports Bidder's protest, and any proposed changes to the requirements. The EWEB Purchasing department shall promptly respond to each written protest, and where appropriate, issue all revisions, substitutions, or clarifications via Addenda to all Bidders. Bidders must exhaust all administrative remedies before seeking judicial review.

1.7 PROPOSER'S PROPOSED TERMS AND CONDITIONS Rule 3-0230(7)(b)

Bidders may include in the Cover Letter of their response, proposed revisions to the contractual terms and conditions in the MS Word Sample Contract (Exhibit 1). (Bidders may show proposed changes by using Word Track Changes tool *OR* providing proposed revisions in cover letter.) Bidders may not protest or request to change the entire terms and conditions of the solicitation. For example, you may not seek to replace EWEB's terms and conditions in whole with your company's terms and conditions, standard contract, master services agreement, etc.

EWEB reserves the right to negotiate the proposed terms and/or conditions with Bidder, and either accept or reject the proposed terms and/or conditions. **REQUESTS FOR REVISION OF EWEB CONTRACTUAL TERMS AND CONDITIONS MAY BE MADE AT TIME OF BID SUBMISSION. THERE MAY BE NO OPPORTUNITY TO DO SO AT A LATER DATE.**

NO PROPOSED TERMS OR CONDITIONS SHALL BECOME A PART OF THE AWARDED CONTRACT UNLESS ACCEPTED BY EWEB AND INCORPORATED INTO THE CONTRACT IN WRITING.

1.8 SIGNATURE ON BID

Bids shall be signed by an authorized representative of the Bidder. Signature on a bid certifies that the bid is made without connection with any person, firm or corporation making a bid for the same goods and/or services and is in all respects fair and made without collusion or fraud. Signature on a bid also certifies that the Bidder has read, fully understands and agrees with all bid specifications, terms and conditions. No consideration will be given to any claim resulting from bidding without fully comprehending all requirements of the Invitation to Bid.

Bidders shall only enter information within the bid document where it is requested or required. Bidders shall NOT make any alterations to the original solicitation document. Any bid that has been altered may be rejected.

1.9 CANCELLATION, REJECTION, DELAY OF SOLICITATION

Pursuant to EWEB Rule 3-0640, EWEB may cancel, reject in whole or in any part any bids, at any time after issuing the ITB, without liability incurred by EWEB, if EWEB believes it is in EWEB's best interest to do so.

1.10 RESERVED

BID SUBMISSION

1.11 BID SUBMISSION

(A) OregonBuys Electronic Response

Please be sure to combine all documents into one pdf file before attempting to submit your bid into the OregonBuys bid site.

In order to submit an electronic bid on the OregonBuys website, Bidder must be registered with OregonBuys and able to submit an electronic bid. For instructions to register on OregonBuys, visit the following site: [OrBuysSupplierRegistrationSteps.pdf \(oregon.gov\)](#)

If you experience any issues registering, please contact OregonBuys at:

Phone: 1-855-800-5046

Email: support.oregonbuys@das.oregon.gov

When Bidder is submitting their proposal electronically, Bidder should follow the procedures outlined in any of the following:

<https://www.oregon.gov/das/ORBuys/Documents/OregonBuys%20Vendor%20Formal%20Solicitation%20Response.pdf> for electronic submission.

A video presentation on submitting an electronic proposal may be found at: [Supplier - Submitting a Quote - Overview \(periscopeholdings.com\)](#)

Terminology specific to the OregonBuys system may be found at:

<https://www.oregon.gov/das/ORBuys/Documents/Phase1TerminologyCrosswalk.pdf>

Bids received in a manner other than through the OregonBuys website and/or after the closing date and time will not be considered and will be rejected. EWEB is not responsible for proposals submitted in any manner format or to any delivery point other than as required by the Solicitation document.

(B) REQUIRED BID PACKAGE

Complete, sign, and return the following documents as bid response. *Failing to include these documents could lead to rejection of bid.*

- Cover Letter
- Bid Form (Section 4)
- All Posted Addenda Acknowledged

(C) RESPONSIVENESS / RESPONSIBILITY

A "Responsive" bid is a bid that substantially complies with the Invitation to Bid instructions and requirements.

A "Responsible" Bidder can demonstrate ability to meet the requirements of the Scope of Work, has the appropriate experience, is legally qualified to do the Work, has the required certifications required, has a satisfactory record of integrity and can meet the other requirements described in ORS 279B.110(2).

1.12 ADDENDA

Any VERBAL communication cannot and shall not be construed as approval of the acceptability of any deviation to any requirement. All changes to requirements and/or the bidding documents will be made in the form of Addenda. The Bidder is responsible for ensuring that all Addenda have been downloaded and are acknowledged in their bid response. Bidder may sign each issued Addendum and include with response or acknowledge in the space provided on the Bid Form.

All Addenda can be obtained electronically at the State of Oregon's bid site ("Oregon Buys"): <https://oregonbuys.gov/bsa/>. As a courtesy, EWEB may send Addenda to registered Bidders by e-mail.

1.13 BID MODIFICATION

If a Bidder wishes to make modifications to a submitted Bid, Proposer must do so through OregonBuys prior to the Bid Due Date and Time stated on the Cover Page for this ITB. For help, please call OregonBuys at 1-855-800-5046.

1.14 BID WITHDRAWALS:

If a Bidder wishes to withdraw a submitted Bid, Bidder must do so through OregonBuys, using the "Withdraw Quote" button prior to the Bid Due Date and Time stated on the Cover Page for this ITB. For help, please call OregonBuys at 1-855-800-5046.

1.15 EXCEPTIONS

Any exceptions to the requirements of this solicitation MUST be submitted in accordance with Item 1.6 PROTEST OF SPECIFICATIONS / REQUIREMENTS. Exceptions submitted with your bid, or in any manner other than the process provided herein, may cause your bid to be ruled non-responsive and rejected.

1.16 ALTERNATE BIDS

Bidders may submit more than one offer. All offers must comply with the requirements of the ITB except that additional offers may incorporate, by reference, repetitive information which is provided in the complete offer.

1.17 BID OPENING/REQUEST FOR CLARIFICATIONS:

Bids received in response to this Invitation to Bid shall be opened at the scheduled closing date and time by EWEB Purchasing department. Bidders shall be informed only of the names of Bidders submitting bids and the total bid price. No other information shall be available at that time. Award decisions will NOT be made at the opening. Bidders wishing to view the Bid Opening may do so remotely and shall contact the Buyer at least 24 hours ahead of the bid opening to receive an MS Teams link.

After bid opening, EWEB may conduct discussions with apparent responsive Bidders for the purpose of clarification to assure full understanding of the bid. All bids needing clarification, in EWEB's sole discretion, shall be accorded such an opportunity. EWEB shall document clarification of any Bidder's bid.

EWEB reserves the right to waive any or all informalities and irregularities per EWEB Rule 3-0470.

1.18 METHOD OF BIDDING

Bidders shall bid in the space(s) provided all information required on the Bid Form. Failure to do so may result in bid rejection.

The price of each item shall be clearly shown in the space provided. The price of each item shall be extended to show the total when required. In case of errors in extension, the unit price shall prevail.

1.19 PROPRIETARY DATA/PUBLIC RECORD

This Invitation to Bid, together with copies of all documents pertaining to the award of a contract, shall be kept by EWEB and made a part of a file or record which shall be open to public inspection. If a bid contains any information that is considered a trade secret under ORS 192.345(2), each sheet of such information shall be marked with the following legend:

"This data constitutes a trade secret under ORS 192.345(2), and shall not be disclosed except in accordance with the Oregon Public Records Law, ORS Chapter 192."

The Oregon Public Records Law exempts from disclosures only bona fide trade secrets, and the exemption from disclosure applies only "unless the public interest requires disclosure in the particular instance" ORS 192.345(2). Therefore, non-disclosure of documents or any portion of a document submitted as part of a bid may depend upon official or judicial determinations made pursuant to the Public Records Law.

The above restriction may not include cost or price information, which shall be open to public inspection.

BID EVALUATION & AWARD

1.20 METHOD OF AWARD

Award shall be made to the lowest responsive and responsible Bidder for the total of the items selected for award. Award shall be made to one Bidder and one Bidder only. EWEB reserves the right to withdraw any item(s) from award consideration if it is in the best interest of EWEB to do so.

EWEB reserves the right to make the award by item, groups of items, or entire bid, whichever is in the best interest of EWEB.

1.21 RECIPROCAL PREFERENCE

In determining the "lowest responsible Bidder," EWEB adds a percentage increase to each out-of-state Bidder's bid price that is equal to the percentage given to local Bidders in that Bidder's home state. For

example, if the “lowest responsible Bidder” is from a state that grants a 10 percent preference to local Bidders, EWEB will add 10 percent to that Bidder’s price when evaluating the bid.

1.22 MINIMUM REQUIREMENTS: Evaluation of bids will be based on minimum requirements established by the Technical Specifications / Statement of Work, if any, and compliance with the terms and conditions of the Invitation to Bid.

1.23 INVESTIGATION OF REFERENCES

EWEB reserves the right to request and investigate the references and the past performance of any Bidder with respect to its successful performance of similar services, compliance with specifications and contractual obligations, and its lawful payment of suppliers, subcontractors, and workers. EWEB may postpone the award or execution of the Contract after the announcement of the apparent successful Bidder in order to complete its investigation. EWEB reserves the right to reject any bid response or to reject all bid responses at any time prior to EWEB’s execution of Contract, upon good cause and upon EWEB finding that it is in the public interest.

1.24 PRIOR ACCEPTANCE OF DEFECTIVE BIDS

Due to limited resources, EWEB generally will not completely review or analyze any bid response which on its face fails to comply with the requirements of the bid documents or which clearly is not the best bid, nor will EWEB generally investigate the references or qualifications of those who submit such bid responses. Therefore, neither the release of a Bidder’s bid bond, the return of a bid response, nor acknowledgment that the selection is complete shall operate as a representation by EWEB that a response was complete, sufficient, or lawful in any respect.

1.25 TIME FOR ACCEPTANCE

Bids shall be valid and binding offers for a period of thirty (30) days from the closing date (unless otherwise specified in the solicitation document) and may not be modified or withdrawn after the closing date and time.

1.26 BID RESULTS

To obtain bid results, notes may be taken at the public reading of the bid or a personal inspection may be made of the bid files at a later date, BY APPOINTMENT. Bid tabulations may be obtained electronically at the State of Oregon’s bid site ("Oregon Buys"): <https://oregonbuys.gov/bsol/>. (Search for bid # 26-138-G). EWEB may, as a courtesy, provide the notification of Intent to Award to all participating Bidders.

1.27 PROTEST OF AWARD (EWEB Rule 3-0740)

A Bidder may protest the award or intent to award a contract if: The Bidder is adversely affected because the Bidder would be eligible to be awarded the Contract in the event that the protest were successful; and the reason for the protest is that all lower bids are nonresponsive; or EWEB has failed to conduct the evaluation of bids in accordance with the criteria or processes described in the solicitation document; or EWEB has abused its discretion in rejecting the protestor’s bid as nonresponsive; or EWEB’s evaluation of bids or EWEB’s subsequent determination of award is otherwise in violation of EWEB Rules.

Eligible Bidders protesting award shall follow the procedures described herein. Protests that do not follow these procedures shall not be considered. This protest procedure constitutes the sole administrative remedy available to Bidders.

- a) Protests must be received within seven (7) days after issuance of the Notice of Intent to Award the Contract. EWEB will not consider late protests.
- b) All protests must be in writing, signed by the protesting party or an authorized Agent and submitted to the EWEB Purchasing Contact listed on page 1. The protest must state all facts and arguments on which the protesting party is basing the protest.
- c) Only protests stipulating an issue of fact concerning a matter of bias, discrimination or conflict of

interest, non-compliance with procedures described in the procurement documents, or EWEB policy shall be considered. Protests based on procedural matters will not be considered.

- d) EWEB’s Purchasing Supervisor will review the protest and will email or mail the protesting party a written response within three (3) business days of receipt of the written protest to the email address or postal address provided in the bid or bid. Any written response may be comprised of a determination of the protest, a notice to the protesting party of the need for additional time in which to evaluate the matter, or other notice to the protesting party.
- e) If the Purchasing Supervisor’s determination (response) is adverse to the protester, any further appeal of the Purchasing Supervisor’s determination by the party must be submitted in writing to EWEB’s General Manager within three (3) business days of issuance of the Purchasing Supervisor’s determination (response).
- f) EWEB’s General Manager will review any appeal of the Purchasing Supervisor’s determination and shall email or mail, in accordance with the email address/postal address provided in the bid, the protesting party a written response within three (3) business days of receipt of written appeal.
- g) If the determination of the General Manager is adverse to the protesting party’s interest, the protesting party may only appeal to EWEB’s Board of Commissioners by filing a written notice of appeal to the Board with the General Manager within two (2) business days of issuance of the General Manager’s written determination.
- h) The Contract Review Board, in considering the protest, shall review the documentation presented to the Purchasing Supervisor and the General Manager on or before the next regularly scheduled Board Meeting, but in no event shall they be required to review in less than ten (10) business days, and thereafter, base their decision on such material. The Board review will be limited to the evaluation of compliance with EWEB’s policies and procedures, requirements of the RFP or ITB and the equal and fair application of EWEB’s contracting rules. The Contract Review Board’s determination shall be EWEB’s final decision.

An adversely affected or aggrieved Bidder must exhaust all avenues of administrative review procedures and relief before seeking judicial review of EWEB’s Contractor selection or Contract Award decision.

1.28 RESERVED

1.29 COMMENCEMENT OF WORK

Contractor shall commence no work under the Contract, if awarded, until all certificates of insurance, as required in the Sample Contract (Exhibit #1), have been provided and a Notice to Proceed or a purchase order has been issued by EWEB.

1.30 SCHEDULE OF EVENTS

The schedule of events set out herein represent Eugene Water & Electric Board’s *best estimate* of the schedule that will be followed.

Invitation to Bid Issued	7/7/26
Last Date for EWEB to Receive Protests of Requirements/Specifications/Terms	7/15/26
Last day for EWEB to receive questions from Bidders	7/17/26
Last day EWEB will post Addenda	7/21/26
Closing Date (last day to submit bids to EWEB)	7/28/26
Responses Evaluated	7/28/26-7/31/26

Intent to Award Announcement	8/3/26
Board Approval	9/1/26
Contract Award	TBD

2. SUSTAINABILITY

EWEB is interested in products and services that have a reduced impact on human health and the environment, make the most efficient use of natural resources, and that more fully support communities and economies when compared to competing products and services serving the same purpose. For more information regarding sustainability in procurement and related EWEB policy and plans, please contact EWEB's Purchasing Office at 541-685-7500. The awarded offeror will be expected to support EWEB's goals by implementing the following strategies where applicable.

2.1 WASTE REDUCTION

Pursuant to EWEB's Zero Waste efforts, EWEB aims to prevent waste where possible. In order to increase efficient use of resources, the awarded offeror shall adhere to the following items as applicable.

- 2.1.1 Packaging for goods that is unnecessary beyond packaging compliance or practical safe shipping methods shall be reduced. Offeror to ship goods using one or more of the following methods:
 - a. Ship products in reusable, refillable, or returnable containers. For example, reusable trays or totes, which can be stored and returned;
 - b. Minimal packaging material used inside containers. This includes eliminating or reducing the amount of non-recyclable bubble wrap, foam pellets or other like material;
 - c. Eliminate non-essential parts of packaging, such as individual wrapping of components;
 - d. Use packaging made with recycled content, biodegradable, and/or non-toxic materials.
 - e. No point of purchase material or promotional literature.
- 2.1.2 The awarded offeror is to duplex all paper materials that are prepared for EWEB under the Contract, whether such materials are printed or copied, except when impracticable to do so due to the nature of the product being produced.

2.2 FUEL REDUCTION

- 2.2.1 EWEB expects suppliers to review the manufacturing process for increased efficiency overtime. Shipping should be routed efficiently with efforts made to ship in the shortest and most efficient route. EWEB prefers to receive shipments in full rather than receiving multiple shipments.
- 2.2.2 In the interest of reducing air and noise pollution, greenhouse gas emissions and promoting energy conservation, all gasoline and diesel powered vehicles and equipment shall be idled only as necessary to perform the required duties, including delivery, and for the essential function(s) of the equipment. A driver of a vehicle must turn off the engine upon stopping at the destination, and must not cause or allow an engine to idle at any location for more than 20 seconds. This idling policy applies except in the following situations:
 - a. The health and safety of employees, subcontractors or public is compromised by turning off the vehicle.
 - b. The engine is required to power auxiliary equipment (e.g. hoist, lift platforms, hydraulic tools, inverters, compactors, medical equipment, specialized public safety radio communication and computer systems, etc.)
 - c. Vehicle/equipment manufacturer requires additional idle time for warm up or cool down for efficient and proper mechanical or functional operation of the unit.

2.3 ENVIRONMENTALLY PREFERRED PRODUCTS

To promote and encourage environmentally sustainable practices for companies doing business with EWEB, EWEB requests vendors under EWEB contract use environmentally preferable products in production of EWEB work products.

2.3.1 The awarded offeror should use environmentally preferable materials that meet performance requirements wherever practical in the fulfillment of this agreement. Environmentally preferable products and services have characteristics that include but are not limited to the following:

- Energy efficient
- Non-toxic, non-bio accumulative
- Reusable or upgradeable
- Recyclable
- Contain post-consumer recycled materials
- Produce fewer polluting by-products and/or safety hazards during manufacture, use or disposal, and/or
- Are certified by an independent accredited third party program such as Eco Logo or ENERGY STAR.

2.3.2 EWEB desires the use of post-consumer recycled content, chlorine-free paper to encourage environmentally preferable practices for EWEB business wherever practical in the fulfillment of the Scope of Work.

2.4 **SOCIAL EQUITY**

2.4.1 EWEB supports the use of Minority, Women, Emerging Small Businesses (M/W/ESB), local businesses, Disadvantaged Business Enterprises and Qualified Rehabilitation Facilities (QRF) at both a prime and subcontracting and/or supply chain level. EWEB encourages the awarded offeror to use the following voluntary practices to promote open competitive opportunities for disadvantaged businesses **as applicable**:

- a. Access lists of certified minority, women, emerging small business or disadvantaged business enterprises from the Oregon State Office of Minority, Women and Emerging Small Business (OMWESB) by visiting their website at: <http://www4.cbs.state.or.us/ex/dir/omwesb/>
- b. Visit the Oregon State Qualified Rehabilitation Facilities Program website at <http://dasapp.oregon.gov/qrf/index.aspx> to search for Qualified Rehabilitation Facilities from whom to procure products or services.

2.4.2 EWEB supports the use of safe products to protect the lives of the Contractor, subcontractors, and EWEB employees. Suppliers of products must meet local fire, EPA, and OSHA requirements.

3. TECHNICAL SPECIFICATIONS / SCOPE OF WORK

3.1 **BACKGROUND / OBJECTIVES**

The Eugene Water & Electric Board (EWEB) requires 15kV deadfront padmounted switchgears for use in EWEB's electrical distribution system. The Contractor shall provide all switchgears in strict accordance with the contract specifications. All switchgears shall be new, unused, current production model. No prototype components shall be used. Each switchgears shall include all inspection coupons and warranty identifications cards furnished to general trade.

3.2 **LENGTH OF CONTRACT**

The contract for this project ("Contract") will start from the date of award, and will last approximately five (5) years.

3.3 **TECHNICAL SPECIFICATIONS (OR) SCOPE OF WORK**

All switchgears furnished under the resulting contract shall comply with the applicable attached material specifications:

Exhibit 2: Deadfront Padmounted Switchgear ES5-5.1100 Rev 1

492-00001800: SWITCH PADMOUNT DEADFRONT 9 TWO 3 POLE 600 AMP DISCONNECTS 14.4-17KV TWO 200 AMP 3 POLE FUSE POSITIONS S&C SM-20 FUSE HOLDERS 600 AMP BUSHING WITH REMOVABLE STUDS. EWEB SPECIFICATION ES5-5.1100 REV 1

492-00001802: SWITCH PADMOUNT DEADFRONT 11 THREE-3 POLE 600 AMP DISCONNECTS 14.4-17KV ONE 200 AMP 3 POLE FUSE POSITION S&C SM-20 FUSE HOLDERS 600 AMP BUSHINGS WITH REMOVABLE STUDS. EWEB SPECIFICATION ES5-5.1100 REV 1

492-00001803: SWITCH PADMOUNT DEADFRONT 5 ONE 3-POLE 600 AMP DISCONNECT ONE 3-POLE 200 AMP FUSE POSITION 14.4-17KV. EWEB SPECIFICATION ES5-5.1100 REV 1

All goods furnished under the resulting Contract shall comply with the applicable attached material specification shown in **Exhibit #2** below.

Contractor is responsible for constructing and providing all *goods* in accordance with the specifications. Any deviations from the specifications provided in this Contract shall be requested by Contractor in writing and agreed to by EWEB in the form of an Amendment to this Contract. Any errors, confusion, or alterations in Contractor's drawings that differ from the material specifications of this Contract shall NOT be considered accepted by EWEB, whether-or-not EWEB signs-off on the drawing, unless an Amendment acknowledging and accepting the change has been executed by EWEB.

Contractor is responsible for any and all costs associated with correcting goods that are not built in compliance with the requirements of this Contract, including all freight charges incurred for the return and re-shipment of deficient goods.

3.4 **SILENCE OF SPECIFICATIONS**

If any omitted specification results in ambiguity as to material characteristics of the goods, and the inclusion of that specification is necessary to enable a reasonable person to properly identify such characteristics, the Bidder shall use the Protest of Specifications procedure found in Section 1.6 to request the needed specification or clarification. Contract acceptance of any apparent silent specification's or supplemental specification's detail, or the apparent omission of a detailed description concerning any point, is agreed by the parties to mean the best commercial practice and/or the highest quality materials and workmanship for the price bid.

3.5 **ESTIMATES NOT BINDING**

The bid form gives the estimated annual usage for each line item; however, any estimate of the number of goods required by EWEB are for bidding purposes only and are provided as a courtesy to our Bidders. EWEB makes no guarantee of the actual number of goods that will be purchased (that number

may be more or less than those indicated). The Bidder shall not rely upon those numbers as a guarantee of the purchases from the resulting Contract.

3.6 ORDERING

Items will be ordered on an as-needed basis.

3.7 DELIVERY

Switchgear shall be delivered no later than 90 days after receipt of purchase order, unless otherwise negotiated and agreed to by EWEB. Failure to provide a delivery schedule may result in bid rejection. Contractor shall be responsible for all transportation, handling, and delivery charges, including any resulting back orders.

EWEB's Transformer Shop shall be notified a minimum of two working days (48 hours) before delivery day. The successful bidder will be given the name and phone number of the Transformer Shop contact person at the time of the award of the contract.

Delivery hours are 9 a.m. to 3:00 p.m. Monday through Thursday, except EWEB holidays.

3.8 EMERGENCY PURCHASES / EXPEDITED DELIVERY

In the case of an emergency where EWEB requires expedited delivery and receipt of goods, and when Contractor cannot meet EWEB's expedited delivery requirements, EWEB reserves the right to purchase goods from other sources.

3.9 WARRANTIES

EWEB requires a minimum warranty period of eighteen (18) months after the date of acceptance unless Contractor routinely and normally offers an extended period beyond the eighteen months, which extended period shall apply to this product/equipment.

Unless otherwise stated, all equipment shall be free and clear of any liens or encumbrances and shall be new and the current model and shall carry full manufacturer warranties.

Contractor warrants to EWEB that any goods/equipment furnished will operate and function in the manner represented by Contractor and will achieve the performance stated in the material specification when operating within the design conditions described therein.

Contractor warrants the goods/equipment furnished is free from defects in material and workmanship, and agrees to repair or replace any unit that is unsuitable for operating or fails in operation during normal and proper use, including all parts and labor at no cost to EWEB.

4. BID FORM

Bids should be prepared and organized in a clear and concise manner and must include all information required by this ITB. Separate and clearly identify all sections and include a Table of Contents. Headers, titles and tabs should be used to identify required information.

RETURN THE FOLLOWING WITH YOUR BID RESPONSE, PER SECTION 1.11(B):
(Failing to include these documents could lead to rejection of bid.)

(Place a check in front of the item indicating inclusion in your response.)

- COVER LETTER
- BID FORM – Section 4
- ALL POSTED ADDENDA ACKNOWLEDGED
- ALL DOCUMENTS COMBINED INTO ONE PDF FILE

A. BID PRICE

The Undersigned hereby offers to furnish all switchgears as specified herein in strict accordance with the Bid Documents, and for the following amount(s). Prices include all costs related to shipping and handling:

ITEM	DESCRIPTION	EST. Annual QTY.	UNIT	UNIT PRICE	TOTAL PRICE
1.	SWITCH PADMOUNT DEADFRONT 9: EWEB Item 492-0001800 Mfg: _____ Model: _____ Part Number: _____	5	EA	\$ _____	\$ _____
2.	SWITCH PADMOUNT DEADFRONT 11: EWEB Item 492-0001802 Mfg: _____ Model: _____ Part Number: _____	3	EA	\$ _____	\$ _____
3.	SWITCH PADMOUNT DEADFRONT 5: EWEB Item 492-0001803 Mfg: _____ Model: _____ Part Number: _____	1	EA	\$ _____	\$ _____

TOTAL BID \$ _____

DELIVERY: _____ days ARO

WARRANTY: _____ (Must be a minimum of 18 months)

REFERENCES

Bidders are requested to provide three (3) **current** references that they have had continuous experience with over the last five years. References are to be for deadfront padmounted switchgears manufactured for utilities in the western United States. Bidders are to include the contact name, company name, description of Switchgear supplied, phone and email. Failure to submit references may result in bid rejection.

Reference 1:

Contact Name _____ Company Name _____

Phone # & Email _____

Switchgears Supplied _____

Reference 2:

Contact Name _____ Company Name _____

Phone # & Email _____

Switchgears Supplied _____

Reference 3:

Contact Name _____ Company Name _____

Phone # & Email _____

Switchgears Supplied _____

B. PROPOSED TRANSPORT

Bidder shall indicate below the method that will be used to deliver goods:

_____ COMMERCIAL/Common CARRIER _____ COMPANY OWNED/RENTED/LEASED VEHICLE

If Bidder is using anything other than commercial/common carriers to deliver goods, an insurance certificate for Automobile Liability as listed in Section 14 of Exhibit #1 Sample Contract must be provided prior to the issuance of a Notice to Proceed.

C. ACKNOWLEDGMENT OF RECEIPT OF ADDENDA TO BID DOCUMENTS:

Bidder acknowledges receipt of Addenda and agrees to be bound by their contents.

Circle each ITB Addendum received: 1, 2, 3, 4, 5, 6, 7, 8, 9, 10

Check if not applicable or no Addenda were received: _____

D. MWESB STATUS

EWEB encourages contracting with minority owned, woman owned, and emerging small businesses (MWESB). The State of Oregon offers a certification process. Indicate below if your business is a MWESB and if so, which categories have been state certified.

MWESB Certified? (Indicate Yes or No) _____

If yes, please indicate which of the following applies: _____

Minority Owned, Woman Owned, Emerging Small Business, or Veteran Owned

E. ACKNOWLEDGEMENT OF INDEPENDENT CONTRACTOR STATUS

The undersigned acknowledges that:

1. Contractor certifies its status as an independent contractor in satisfaction of Oregon law, including ORS 670.600, and shall perform all required Work as an independent contractor. EWEB holds the right (i) to determine the delivery schedule for the Work to be performed and (ii) to evaluate the quality of the completed performance, but EWEB cannot and will not control the means or manner of Contractor's performance. Contractor is responsible for determining the appropriate means and manner of performing the Work.
2. The parties covenant that Contractor, its subcontractors, agents, officers and representatives do not qualify as officers, employees, or agents of EWEB as those terms are used in ORS 30.265 nor shall they seek such qualification relating to performance of the Work.
3. Contractor agrees it is responsible for all federal and state taxes or other payments or withholdings applicable to compensation or payments paid to Consultant under this Contract and shall hold EWEB harmless from such financial exposures.

F. SUSTAINABILITY QUESTIONNAIRE

The Supplier Sustainability Questionnaire must be completed and returned with your bid/proposal. This questionnaire is applicable to firms that provide services and/or goods. Responses can be up to 4 pages in length.

1. What policies or plans are in place to help decrease environmental or social impacts from your supply chain or manufacturer (if company is a distributor) such as decreasing use of toxic or hazardous products, efficient use of natural resources, reducing greenhouse gas emissions, waste reduction, and worker health and safety? Please provide links to documents. How does your company monitor and manage your supply chain with regard to environmental and social issues?
2. What type of sustainable packaging/shipping materials do you use, such as reusable, recycled content, or compostable materials? Does your company have a Zero Waste Plan; if so describe the progress your company has made to implement the plan. If you don't use sustainable packaging please detail why not.
3. Does your company have transportation strategies to reduce fossil fuel, maintain local warehouses to shorten shipping distances and lead times, or combine shipments to receive economies of scale? If so, please include link or details of plan.
4. Has your company been cited in the last 5 years for non-compliance of any permits, rules or regulations pertaining to environmental, health and/or safety? If yes, please state the reason, and outcome of the citation including a description of the steps taken by your company to rectify the problem.
5. What programs do you have in place, or are planned for to increase resource efficiency such as reducing use of electric, water, labor or material resources?
6. Have the product(s) that you are bidding/proposing been certified by a third-party organization, such as Green Seal, Ecobiz, or ENERGY STAR. If yes, detail which ones and the relevant third party certification?

G. BIDDER RESIDENCY

ORS 279A.120 states, "For the purposes of awarding a public contract, a contracting agency shall":

- (a) Give preference to goods or services that have been manufactured or produced in this state if price, fitness, availability and quality are otherwise equal; and
- (b) Add a percent increase to the bid of a nonresident bidder equal to the percent, if any, of the preference given to the bidder in the state in which the bidder resides.

“Resident Bidder” means a bidder that has paid unemployment taxes or income taxes in this state during the 12 calendar months immediately preceding submission of the bid, has a business address in this state and has stated in the bid whether the bidder is a “Resident Bidder” under this paragraph.

“Non-Resident Bidder” means a bidder who is not a “Resident Bidder” as defined above

a. CHECK ONE: Bidder is a () RESIDENT Bidder () NON-RESIDENT Bidder.

b. If Resident Bidder, enter your Oregon business address: (physical and mailing address)

c. If a Non-Resident Bidder, enter state of residency:

d. If a Non-Resident Bidder, do you or your Company receive, or are you or your Company eligible for any preference in award of contracts with your state’s government or with other governmental bodies in your state?

CHECK ONE: () YES () NO

If YES, state the preference percentage: _____%

If YES, but not a percentage of bid price, describe the preference:

If YES, state the law or regulation that allows the preference described (legal citation):

H. ASSURANCES:

The undersigned attests that they:

- Have read and understand all instructions, requirements, Addenda, site conditions, and terms and conditions contained herein (including the attachments and exhibits listed in this solicitation).
- Have the authority and/or responsibility to submit a bid and to bind their organization in all phases of this solicitation process.
- Confirm the information provided is true and accurate to the best of their knowledge.
- Understand that any false statement may disqualify this offer from further consideration or may be cause for Contract termination.
- Have not and will not discriminate against a subcontractor in the awarding of a subcontract because the subcontractor is a disadvantaged minority, women or emerging small business enterprise certified under ORS 200.055.
- Represent and warrant to EWEB that they have the power and authority to enter into and perform work under an awarded Contract. When executed by EWEB and Contractor the Contract shall be a valid and binding obligation of Contractor enforceable in accordance with its terms.
- Arrived at the specifics of the bid, including price and amounts, independently and without communication or agreement with another Bidder, except as disclosed in a separately attached statement.
- Are not submitting the bid in the interest of or on behalf of any undisclosed person;

- Have not directly or indirectly induced or solicited another Bidder, in order to benefit a third person, to submit a false or sham bid, to refrain from bidding or to change a bid.
- Have not directly or indirectly disclosed the Bidder's bid price, a breakdown of the price, the contents of the price or information or data related to the price to another Bidder.
- Have not sought through communication or agreement with a person to fix the bid price of the Bidder or another Bidder, to fix an overhead, profit or cost element of the bid price of the Bidder or another Bidder or to secure any advantage against the contracting agency or any other person interested in the public Contract.
- Have not directly or indirectly expressed an interest or lack of interest in the public Contract, or paid or offered to pay a fee to a person, to cause a collusive or sham bid.

I. SOLICITATION SIGNATURE

Contractor by signing this Bid Form represents and warrants that Contractor's performance under an awarded contract will create no potential or actual conflict of interest, including but not limited to conflicts of interest as defined in ORS 244.020. Contractor further warrants that no state or federal law or EWEB rule will prevent Contractor's lawful performance of an awarded contract. If Contractor is currently performing work for EWEB or another governmental entity, Contractor's participation in other public contracts will not create a potential or actual conflict of interest in performance of a Contract resulting from this ITB, if awarded.

BIDDER INFORMATION:

Bidder Company Name

Company Address (from which product will be shipped or work will be performed)

Telephone Number

Federal Tax ID Number

Person Signing ITB _____ Title _____
Please print or type name

Signature _____

Email Address _____

Bidder's ITB Representative (if different than above)

Name _____ Title _____
Please print or type name

Signature _____

Phone _____ Email _____



Contract for Goods

Deadfront Padmounted Switchgears 15kV

Contract No. 26-138-G

By and between

Eugene Water & Electric Board

and

Contractor

This Contract is entered into by and between the **Eugene Water & Electric Board**, hereinafter called EWEB, and _____, hereafter called Contractor.

RECITALS

WHEREAS, EWEB has negotiated the following agreement (“Agreement” or “Contract”) in Eugene, Oregon, and Contractor has agreed to deliver its Goods in Eugene, Oregon;

NOW THEREFORE, in consideration of a sum agreed to by the Parties, the Contractor agrees to sell and deliver the Goods as described in this Contract, in accordance with all requirements, terms and conditions of this Contract, as set forth below:

DEFINITIONS

“**Acceptance**” - Goods furnished under this Contract shall be subject to inspection and testing by EWEB at delivery point, or as otherwise stated in the Contract. If EWEB determines that Goods conform in accordance with the Contract Specifications, then EWEB shall notify Contractor that “Acceptance” of the Goods has occurred.

“**Contract**” or “**Contracts**” means the Written agreement(s), resulting from the Solicitation Document that sets forth the rights and obligations of the parties.

“**Contractor**” means the Person with whom EWEB enters into a Contract.

“**Goods**” includes products that have associated or incidental service components, such as supplier warranty obligations or maintenance service programs. (See ORS 279B.115(1))

“**Person**” means a natural person capable of being legally bound, a sole proprietorship, a corporation, a partnership, a limited liability company or partnership, a limited partnership, a for-profit or nonprofit unincorporated association, a business trust, two or more persons having a joint or common economic interest, any other person with legal capacity to contract or a public body.

“**Rule**” means a Rule within the EWEB Public Contracting Rules.

“**Services**” under this Contract mean any action or work to be performed by the Contractor in the provision of the Goods required under the Contract.

“**Specifications**” under this Contract sets forth the required design and minimum level of quality of the Goods furnished by Contractor under this Contract.

“**Work**” means the furnishing of all materials, equipment, labor, and incidentals necessary to successfully complete any individual item or the entire Contract and successful completion of all duties and obligations imposed by the Contract.

“**Working hours**” means EWEB’s regular business hours, which currently are Monday through Friday, 9 a.m. to 5 p.m., excluding EWEB recognized holidays.

All other terms not expressly identified in the Contract shall have the meanings as set forth in EWEB Public Contracting Rules, Division 1 - Definitions.

ARTICLES

HEADINGS: The section (“Section” or “Article”) headings in this Contract are included for convenience only; they do not give full notice of any portion of the terms of this Contract.

CONTRACT COMMENCEMENT

1. Effective Date and Duration

This Contract shall become effective on the date this Contract has been signed by every party hereto and, when executed by EWEB's Purchasing Supervisor. Unless terminated in accordance with the early termination provisions in Section 12, this Agreement will automatically renew on the anniversary of the original Contract Execution Date. If Contractor does not agree to renew the Agreement for an additional term, Contractor must notify EWEB within 90 days of the anniversary of the original Contract execution date. The maximum term for this Agreement shall not exceed five (5) years.

PRICING AND PAYMENT

2. Contract Compensation

The maximum, not-to-exceed compensation payable to Contractor under this Contract, which includes any allowable expenses, is \$ _____. Pricing detail is provided in Attachment A – Schedule of Goods.

Pricing and Payment

3. Invoicing and Payment

a. Interim payments to Contractor shall be made according to the following:

Payment Submission: Invoices shall be submitted to EWEB's Contract Administrator and accountspayable@eweb.org for this Contract. EWEB's Contract Administrator is Tom Ossowski.

Payment Terms: EWEB will make payment in accordance with its regular payment schedule: Net 30 days from receipt of a valid, undisputed invoice.

b. Payment for undisputed amounts will be made upon receipt of an invoice and after product successfully passes an inspection at the delivery location and is in full compliance with the Specifications of the solicitation, including manuals, data sheets, or any other required component.

4. Price Adjustments

Price increases may be considered by EWEB quarterly prior to the beginning of the next quarter term. Contractor is responsible for submitting their request for any price increase before the start of the new quarter, **without exception**, as detailed in Attachment A. Contractor must provide a positive means of substantiating any price increase by providing supporting documentation before the start of the new quarter. EWEB shall determine what constitutes acceptable documentation.

Upon receipt of request, EWEB reserves the right to (1) accept or negotiate the requested price increase and extend the Contract/allow the Contract to automatically renew or (2) reject the price increase and allow the Contract to expire.

EWEB shall be given the immediate benefit of any price decrease. Contractor shall promptly notify EWEB's Purchasing Department of the amount and effective date of each decrease. Decreases shall apply to purchases on or after the effective date of the decrease.

SPECIFICATIONS / REQUIREMENTS

5. Schedule of Goods

An overview of the Goods required is contained in Attachment A - Schedule of Goods, attached and incorporated by reference into this Contract.

6. Specifications

Contractor shall deliver all Goods and Services specified under the Contract in accordance with the Specifications contained in Attachment A. Contractor's failure to deliver Goods in accordance with the provisions of this Contract is a material breach of this Contract.

a. General provisions.

- i. Standard Components. Unless specified otherwise in this Section, Contractor shall provide Goods with all components and accessories that the manufacturer lists as "standard" for Goods.
- ii. Necessary Components. Unless specified otherwise in this Section, Contractor shall include all components, hardware and parts necessary for complete and proper assembly, installation and operation of Goods.
- iii. New and Unused Goods. Unless specified otherwise in this Section, Contractor shall deliver Goods that are new, unused and produced from current production inventory. Contractor shall provide Goods manufactured from only those components that the manufacturer offers in the manufacturer's current parts catalogue for Goods.

b. Detailed Specifications.

All Goods furnished under the resulting Contract shall comply with the applicable attached material specification contained in Attachment A – Schedule of Goods.

7. Addition/Deletion and Product Substitution of Goods

Contractor will make available to EWEB products that have been added to the product line by the manufacturer or products in the same product line not specifically listed in this Contract. These products will be available at pricing and discount consistent with current items available under the Contract.

EWEB reserves the right to remove any product that has demonstrated to be unsatisfactory under the Contract and purchase replacement product from alternative sources. Upon EWEB's determination that a product under the Contract is unsatisfactory, EWEB will notify Contractor upon discovery and remove the product from the Contract.

Any substitution(s) for originally contracted item(s) must have the approval of EWEB prior to any substitution. If approved by EWEB, the substituted item(s) must be offered to EWEB at no increase in cost and the quality cannot be less than the originally contracted item. Contractor shall be responsible for securing all approvals and will also be responsible for all charges such as freight, storage, labor, etc., which accrue to any shipments of unauthorized substituted material. EWEB will not be responsible to pay for shipments of unauthorized product.

PERFORMANCE

8. On-Time Delivery

- a. All Goods shall be received by the Required Date specified on each purchase order issued. Additional detail regarding delivery is provided in Attachment A - Schedule of Goods.
- b. All deliveries shall be F.O.B. destination with all transportation and handling charges paid by Contractor, unless specified otherwise in the Contract. Responsibility and liability for loss or damage shall remain with Contractor until final inspection and Acceptance.

- c. Time is of the essence in the performance of this Contract. Contractor shall deliver within the time indicated above OR on the purchase order issued by EWEB. Should Contractor fail to meet the agreed-upon delivery schedule, thereby making it necessary for EWEB to purchase urgently needed items from another source, and if the alternative Goods are at a higher price than Contractor's contracted price, Contractor shall pay the difference between the contracted price and the purchase price from alternative source, as allowed by the UCC, as adopted by Oregon, whichever is in the public's best interest as determined by EWEB. Purchase shall be for the same product or an equivalent.

9. Inspections

Goods furnished under this Contract shall be subject to inspection and testing by EWEB within five (5) business days from time of receipt. If EWEB determines that Goods conform in accordance with the Contract Specifications, then EWEB shall promptly notify Contractor that Acceptance of the Goods has occurred or, if the Goods are found to be incomplete and/or not in compliance with Contract requirements and Specifications, that Non-Acceptance/Rejection of the Goods has occurred.

10. Deficiencies and Remedies

- a. If EWEB determines that any Goods are not Acceptable and that any deficiencies are the responsibility of the Contractor, EWEB, at its sole discretion, reserves the right to Reject all or part of the shipment and issue a Notice to Cure and require Contractor to correct any defects without charge. If EWEB elects to allow Contractor opportunity to correct deficiencies, EWEB shall prepare a detailed Notice to Cure, including a written description of such deficiencies and an associated time frame for correction (after conferring with Contractor) and deliver such formal notice to Contractor. Upon receipt of such written notice, Contractor will correct any such failures within the timeframe EWEB specified in its notice and shall re-deliver the Goods to EWEB for re-inspection, all at no additional charge to EWEB.

Contractor Cures Defects - If EWEB determines that Goods conform in accordance with the Specifications, then EWEB shall notify Contractor that Acceptance of the Goods has occurred.

Contractor Failure to Cure Defects - If the Goods still fail to conform as required, EWEB reserves the right to allow Contractor additional opportunities to correct the Goods, again at no additional charge to EWEB. If Contractor is ultimately unable to cure any defects within the time set forth in its formal notice, EWEB may Reject the Goods and cancel the Contract in whole or in part, per Section 12 Early Termination and Contractor shall issue an invoice reversing all charges associated with the Goods and their delivery. EWEB will return defective Goods at Contractor's request, entirely at Contractor's cost for transport.

- b. Timing of Warranty - Once Goods are Accepted, Contractor's warranty shall cover any discoverable deficiencies within the warranty period indicated in the Warranty document (Attachment x) and per Section 11 – Warranties below.
- c. Nothing in this paragraph shall in any way affect or limit EWEB's rights as buyer under the UCC, including the rights and remedies relating to Rejection under ORS 72.6020 and revocation of acceptance under ORS 72.6080.

11. Warranties

Unless otherwise stated, all Goods shall be free and clear of any liens or encumbrances and shall be new (and, if applicable, the current model) and shall carry full manufacturer warranties that meet the requirements in the Contract specifications or Attachment A – Schedule of Goods. Contractor warrants all Goods delivered to be free from defects in labor, material and manufacture and to be in compliance with the Specifications set out in this Contract. All implied and express warranty provisions of the UCC, as adopted in Oregon, are hereby incorporated by reference. (Warranty is attached as Attachment XXXX.)

EARLY TERMINATION

12. Early Termination

This Contract may be terminated as follows:

a. Termination for Convenience

1. EWEB and Contractor, by mutual written agreement, may terminate this Contract at any time.
2. EWEB in its sole discretion may terminate this Contract for any reason on 30 days written notice to Contractor.

b. EWEB Termination for Cause

1. **EWEB Non-Appropriation of Funds** - If payment for Goods purchased under this Contract extends into EWEB's next fiscal year, EWEB's obligation to pay for such Deliverables is subject to approval of future appropriations to fund this Contract by the EWEB Board of Commissioners. If EWEB fails to receive funding, appropriations, limitations or other expenditure authority at levels sufficient to pay for Contractor's Work, EWEB shall terminate the Contract immediately.
2. **Regulatory Changes** - EWEB may terminate this Contract if Federal or state laws, regulations or guidelines are modified or interpreted in such a way that either the Work under this Contract is prohibited or EWEB is prohibited from paying for such Work from the planned funding source. Termination shall take effect on the date the law, regulation or guidelines takes effect, or with 30 days written notice, whichever comes first.
3. **Contractor Loss of Licensure** – EWEB may terminate this Contract immediately if Contractor no longer holds an applicable license or certificate required to deliver the Goods required by the Contract.
4. **Contractor Breach of Contract** - EWEB may terminate this Contract if Contractor commits any material breach or default of any covenant, warranty, obligation or agreement under this Contract, fails to perform the Work under this Contract within the time specified herein or any extension thereof, or so fails to pursue the Work as to endanger Contractor's performance under this Contract in accordance with its terms, and such breach, default or failure is not cured within the time specified in the Notice to Cure issued by EWEB. If Contractor fails to cure the breach or default, Contract will be formally terminated either upon the date specified in the Notice to Cure or on the date specified in a separate Notice of Contract Termination issued by EWEB.

c. Contractor's Right to Terminate for Cause

1. EWEB Non-payment - Contractor may terminate the Contract within 15 calendar days after receipt of Contractor's notice, or such longer period of cure as Contractor may specify in its notice, if EWEB fails to pay Contractor under a formally issued purchase order for Accepted Goods pursuant to the terms of this Contract.
2. EWEB Material Breach of Contract - Contractor may terminate this Contract, for reasons other than nonpayment, if EWEB commits any material breach or default of any covenant, warranty, obligation or agreement under this Contract, fails to perform under the Contract within the times specified, or so fails to perform as to substantially endanger Contractor's performance under this Contract, and such breach, default or failure is not cured within 15 business days after delivery of Contractor's notice, or such longer period as Contractor may specify in such notice, whichever is the longer period.
3. EWEB Rejection of Requested Price Increase - Contractor may opt to terminate this Contract with 6 months formal written notice of termination if EWEB rejects requested price increases, per Section 4 of this Contract.

13. Payment Upon Early Termination

Upon termination pursuant to Section 12, payment shall be made as follows:

- a. If terminated for any reason other than EWEB's Termination due to Contractor breach of Contract, EWEB shall pay Contractor for all Goods delivered under any formal EWEB purchase order issued prior to the email date of Notice of Termination ("Termination Date") if Goods are Accepted by EWEB in accordance with the Contract requirements and terms. EWEB will not pay for Non-Accepted Goods and will return them to Contractor FOB Shipping Point, if Contractor authorizes within 15 business days. EWEB shall not be liable for direct, indirect, special, or consequential damages. Termination shall not result in a waiver of any other claim EWEB may have against Contractor.
- b. Termination by EWEB for Contractor Breach of Contract - If terminated under Section 12(B)(4) by EWEB due to a breach by the Contractor, then EWEB shall pay the Contractor for all Accepted Goods delivered under authorized EWEB purchase orders, less any other setoff to which EWEB is entitled. EWEB will not pay for Non-Accepted Goods and will return them to Contractor FOB Shipping Point, if Contractor so authorizes within 15 business days. EWEB shall not be liable for direct, indirect, special, or consequential damages. Termination shall not result in a waiver of any other claim EWEB may have against Contractor.

EWEB shall also be entitled to any other equitable and legal remedies that are available.

RISK

14. Insurance

Contractor shall provide certificates of insurance as described below. No work under this Contract shall commence until all insurance requirements have been met.

- a. **Certificates of Insurance.** As evidence of the insurance coverage required by this Contract, the Contractor shall furnish certificate(s) of insurance to the EWEB Purchasing Department, before final award can be authorized and must list the Contract number in the "Description of Operations" section. The insurance coverage required under this Contract shall be obtained from insurance companies or entities having a minimum financial rating of A.M. Best's Key Rating A-; VII or higher. The Contractor shall be financially responsible for all deductibles, self-insured retention and/or self-insurance included hereunder.

Contractor shall ensure Contractor's subcontractors procure the same types/categories of insurance as required for Contractor; limits shall be commensurate with each subcontractor's scope of work.

- b. **Commercial General Liability.** Contractor shall obtain, at Contractor's expense, and keep in effect during the term of this Contract, Commercial General Liability Insurance written on the current ISO occurrence form (or a substitute form providing equivalent coverage) including coverage for premises, operations, independent contractors (performing Work on Contractor's behalf), completed operations and contractual liability. The limit shall not be less than \$1,000,000 per occurrence and subject to an aggregate limit of no less than \$2,000,000.

The insurance must include EWEB, its' divisions, officers, and employees as additional insureds and must apply as primary insurance without any contribution from any other insurance or self-insurance afforded to such additional insured. There must not be any endorsement or modification of this insurance to make it excess over any other insurance available to such additional insured. Insurance or self-insurance maintained by EWEB or other additional insureds is in excess of Contractor's insurance, contingent and non-contributory.

The insurance must include a waiver of subrogation in favor of EWEB, its' divisions, officers, and employees.

- c. **Automobile Liability.** Contractor shall obtain, at Contractor's expense, and keep in effect during the term of this Contract, Automobile Liability Insurance to cover liability arising out of any auto (including owned, hired and non-owned) used in connection with the Work or Services. This coverage may be written in combination with the Commercial General Liability Insurance. Combined single limit per occurrence shall not be less than \$1,000,000, or the equivalent.

The insurance must include EWEB, its' divisions, officers, and employees as additional insureds and must apply as primary insurance without any contribution from any other insurance or self-insurance afforded to such additional insured. There must not be any endorsement or modification of this insurance to make it excess over any other insurance available to such additional insured. Insurance or self-insurance maintained by EWEB or other additional insureds is in excess of Contractor's insurance, contingent and non-contributory.

The insurance must include a waiver of subrogation in favor of EWEB, its' divisions, officers, and employees.

- d. **Workers' Compensation.** All subject employers working under this Contract are either employers that will comply with ORS 656.017 which requires them to provide Oregon workers' compensation coverage that satisfies Oregon law for all their subject workers, or employers that are exempt under ORS 656.126. [2003 c.794 §76c] In addition, Contractor will obtain, at Contractor's expense, and keep in effect during the term of this Contract, Employers Liability insurance with a limit of not less than \$1,000,000 each accident for bodily injury by accident, \$1,000,000 each employee for bodily injury by disease, and a \$1,000,000 policy limit for bodily injury by disease.

The insurance must include a waiver of subrogation in favor of EWEB, its' divisions, officers, and employees.

- e. **Notice of Cancellation or Change.** There shall be no cancellation, material change, potential exhaustion of aggregate limits or non-renewal of insurance coverage(s) without 30 days' written notice from Contractor or its insurer(s) to EWEB.

Failure to Maintain Insurance - If at any time Contractor fails to maintain insurance complying with the requirements reflected herein, in full force and effect, they shall be responsible for any resulting losses or costs sustained by EWEB and shall hold EWEB harmless from actions brought against Contractor as the result of the absence of the required insurance, and (ii) EWEB shall not be required but may elect to do any of the following: (A) immediately suspend all or a portion of the Work and be entitled to an equitable adjustment in the price, schedule and other terms of the Contract for the impact of the suspension (B) pay premiums or purchase alternate insurance at the Contractor's expense; or (C) pursue such other remedies as may be allowed by law.

Failure to Comply - Any failure to comply with the reporting provisions of this clause shall constitute a material breach of Contract and shall be grounds for immediate termination of this Contract by EWEB.

- f. **Reserved**

- g. **Waiver of Insurance Requirements**

Contractor's failure to provide certificates of insurance as specified herein and/or in the manner specified herein does not constitute a waiver of the insurance requirements. Any waiver of the insurance requirements will only be made in writing.

15. Force Majeure

Unless this Contract is executed to remedy an act(s), occurrence(s), or event(s) stated herein, neither Party shall be liable for delays in the execution of its obligations due to causes beyond its reasonable control, including, but not limited to acts of God, fires, strikes, labor disturbances, floods, epidemics, quarantine restrictions, war, insurrection or riot, acts of a civil or military authority, compliance with priority orders or preference ratings issued by the federal Government, acts of Government authorities with respect to

revocation of export or re-export permits/licenses, wrecks, or unusually severe weather. The parties shall, however, make all reasonable efforts to remove or eliminate such cause of delay or default and shall, upon the cessation of the cause, diligently pursue performance of ~~its~~ their obligations under this Contract.

In the event of any such delay, the required date of services will be extended for a period of time equal to the period of the delay, or as short a period as is reasonably possible.

EWEB may terminate this Contract for Convenience per Sections 12 and 13 upon written notice after reasonably determining that such delay or default will likely prevent successful performance of the Services provided under this Contract due to quality or timing issues.

- 16. Indemnification.** Contractor shall defend, save, hold harmless, and indemnify EWEB, its officers, employees and agents from and against all claims, suits, actions, losses, damages, liabilities, costs and expenses by either Consultant or any third parties resulting from, arising out of, or relating to any error, omission, breach of contractual duty, or negligent act of the Contractor or its officers, employees, subcontractors, or agents in the performance of services under this Contract.

SUSTAINABILITY

17. Sustainability

EWEB requires suppliers to comply with EWEB's Sustainable Purchasing Policy and to implement the following strategies where applicable:

- EWEB aims to prevent waste where possible. Unnecessary packaging should be eliminated and required packaging should be reusable and/or made with recycled content, bio-degradable, and/or non-toxic materials.
- Fuel reduction strategies shall be implemented including efficiencies in shipping techniques, increasing manufacturing efficiencies over time, and reducing the use of idling vehicles. Where the supplier is not in compliance with our Policy, disclosure is required.
- EWEB requests vendors use environmentally preferable products wherever practical. Characteristics of environmentally preferable products include recyclable, energy efficient, non-toxic, and/or certified by an independent accredited third-party program such as EcoLogo or Energy Star.
- EWEB supports the use of Minority, Women, Emerging Small Businesses (M/W/ESB), local businesses, Disadvantaged Business Enterprises and Qualified Rehabilitation Facilities (QRF) at both a prime and subcontracting and/or supply chain level. EWEB encourages the awarded offeror to use the following voluntary practices to promote open competitive opportunities for disadvantaged businesses as applicable.

18. Recyclable Products

Contractor shall use recycled and recyclable products to the maximum extent economically feasible in the performance of the Contract Work set forth in this document. Contractor shall specify the minimum percentage of recycled product in the Goods provided under this Contract. Contractor agrees to abide by all covenants contained in ORS 279B.270, which is incorporated by reference.

EMPLOYEES AND SUBCONTRACTORS

19. Anti-Discrimination

Contractor shall not discriminate based on race, religion, color, sex, marital status, familial status, national origin, age, mental or physical disability, sexual orientation, source of income, or political affiliation in programs, activities, services, benefits or employment. Contractor shall not discriminate against minority-owned, women-owned or emerging small businesses.

20. Equal Opportunity Employer

EWEB is an Equal Employment Opportunity and Affirmative Action employer and requires contractors and their subcontractors to follow EEO/AA practices in their performance of this Contract.

21. Hours of Labor

Contractor shall pay employees for overtime work performed under the public contract in accordance with ORS 653.010 to 653.261 and the Fair Labor Standards Act of 1938 (29 U.S.C. 201 et seq.).

22. Safety and Health Requirements

General Requirements - Contractor warrants Goods provided under this Contract comply with all applicable federal Occupational Safety and Health Administration (OSHA) requirements and with all applicable Oregon safety and health requirements, including those of the Oregon State Workers' Compensation Division.

The Contractor shall comply with all federal, state, and local safety and health regulations and laws including, but not limited to, the following:

- Oregon Revised Statutes - ORS 654 – The Oregon Safe Employment Act
- Oregon Administrative Rules - OAR 437, Divisions 1-3 - The Oregon Occupational Safety and Health Division (Or-OSHA)
- Department of Labor and Industries regulations and laws
- Oregon Department of Transportation regulations and laws
- United States Department of Labor Law - 29 CFR 1910 and 29 CFR 1926 – Occupational Safety & Health Administration

Protection of Workers - Contractor shall take all necessary precautions for the safety of Contractor employees, subcontractors, suppliers, inspectors, and Owner employees on the job site or otherwise engaged in the undertaking of the Work and shall comply with the Contract Documents, best practices, and all applicable provisions of federal, state, and municipal safety laws and building codes to prevent accidents or injury to persons on, about, or adjacent to the premises where the Work is being performed. Contractor shall erect and properly maintain at all times, as required by the conditions and progress of the Work, all necessary safeguards for protection of workers and the public against any hazards created by the Work.

Chemical Hazards - Products which contain hazardous chemicals, as defined by Oregon Administrative Rules Chapter 437, must be labeled, tagged or marked with the following information:

- 1) Identity of the hazardous chemical(s);
- 2) Appropriate hazard warning; and
- 3) Name and address of the chemical manufacturer, importer or other responsible party.

Contractor shall provide EWEB with a Safety Data Sheet (SDS) as defined by the Occupational Safety and Health Administration (OSHA) for any Goods provided under this Contract, which may release, or otherwise result in exposure to a hazardous chemical under normal conditions of use. In addition, Contractor must label, tag or mark such Goods. The Contractor shall keep Safety Data Sheets (SDS) on file at the location where such chemicals are stored, as required by OAR 437-155-025, for the products listed above.

23. Tobacco Free Workplace

EWEB campuses, worksites, vehicles, and equipment (known collectively as “EWEB Campus”), are smoke-free. Contractors and their staff may not use or distribute tobacco products in any EWEB Campus, nor can they inhale, exhale, burn, or carry any lighted smoking material or vapor. Contractors and staff must extinguish or cease use prior to entering any EWEB campus and must dispose of tobacco products appropriately prior to entry. Improper disposal includes littering, spitting smokeless tobacco, or any measure which creates a fire or hazard or could disrupt the campus or worksite.

24. EWEB Payment of Contractor Claims

- a. Contractor shall make payment promptly, as due, to all persons supplying Contractor labor, equipment or material for Work under this Contract; pay all contributions or amounts due the Industrial Accident Fund from Contractor or any subcontractor incurred in the performance of the Contract; not permit any lien or claim to be filed or prosecuted against EWEB on account of any labor or material furnished; and pay to the Department of Revenue all sums withheld from employees pursuant to ORS 279B.220.
- b. If Contractor fails, neglects or refuses to make prompt payment of any claim for labor or services furnished to Contractor or a subcontractor by any person in connection with this Contract as such claim becomes due, EWEB may, but is not obligated to pay such claim to the person furnishing the labor or services and charge the amount of the payment against funds due or to become due Contractor by reason of this Contract. The payment of a claim under this Section shall not relieve Contractor or Contractor's surety from any obligation with respect to any unpaid claims. ORS 279B.220.

25. Payment for Medical Care

Contractor agrees to make payment promptly, as due, to any person, co-partnership, association or corporation furnishing medical, surgical, hospital or other needed medical care to Contractor's employees. Such payment shall be made from all sums which Contractor has agreed to pay for such services and from all sums which Contractor has collected or deducted from the wage of employees pursuant to any law, contract or agreement for the purpose of providing or paying for such services.

All subject employers working under this contract are either employers that will comply with ORS 656.017 or employers that are exempt under ORS 656.126. [2003 c.794 §76c] .

INDEPENDENT CONTRACTOR

26. Independent Contractor / Responsibility for Taxes and Withholding

- a. Any service or provision of Goods by Contractor under this Contract are those of an independent contractor. Contractor and Contractor's subcontractors, employees, agents, and officers certifies its/their status as an independent contractor^s in satisfaction of Oregon law, including ORS 670.600, and shall perform all required Work as an independent contractor. EWEB holds the right (i) to determine the delivery schedule for the Work to be performed and (ii) to evaluate the quality of the completed performance, but EWEB cannot and will not control the means or manner of Contractor's performance. Contractor is responsible for determining the appropriate means and manner of performing the Work.
- b. The parties covenant that Contractor, its subcontractors, Agents, Officers and Representatives do not qualify as officers, employees, or agents of EWEB as those terms are used in ORS 30.265 nor shall they seek such qualification relating to performance of the Work.
- c. Contractor agrees it is responsible for all federal and state taxes or other payments or withholdings applicable to compensation or payments paid to Consultant under this Contract and shall hold EWEB harmless from such financial exposures.

ADMINISTRATION OF CONTRACT AND RECORDS

27. Access to Records

Contractor shall maintain fiscal records and all other records pertinent to this Contract. Records shall be maintained pursuant to generally accepted accounting standards, and other records shall be maintained to the extent necessary to clearly reflect actions taken in the provision of the products required herein. All such records shall be retained and kept accessible for at least three years following final payment. EWEB's authorized representatives shall have the right to direct access to documents, papers and records related to this Contract for the purpose of conducting audits and examinations and making copies, excerpts and transcripts. EWEB shall reimburse Contractor for Contractor's cost of preparing copies.

28. Reserved

29. Publicity

Any publicity giving reference to this solicitation, whether in the form of press releases, brochures, photographic coverage, or verbal announcement, shall be done only after prior approval of EWEB.

The use of media that is intended to identify Contractor as “EWEB” or “EWEB Contractor”, including but not limited to vehicle magnets, decals, clothing, and other signage, is strictly prohibited unless previously authorized by EWEB. If authorized, Contractor is required to keep all such media in a secure location to deter theft.

30. Survival

Termination or expiration of this Contract does not extinguish or prejudice EWEB’s right to enforce the access to records, indemnification, governing law, and remedies provisions contained within this Contract, its attachments, exhibits, and any and all subsequent Addenda or amendments.

31. Subcontracts and Assignment

Contractor shall not subcontract any of the Work required by this Contract or assign or transfer any of its interest in this Contract, without the prior written consent of EWEB. No such written approval shall relieve Contractor of any obligations under this Contract, and any transferee or subcontractor shall be considered the agent of Contractor. Contractor shall remain liable to EWEB under the Contract as if no such transfer or subcontract had occurred.

32. Successors in Interest

The provisions of this Contract shall be binding upon and inure to the benefit of the parties and their successors and approved assigns, if any.

33. No Third-Party Beneficiaries

EWEB and Contractor are the only parties to this Contract and are the only parties entitled to enforce its terms. Nothing in this Contract gives or provides any benefit or right, whether directly, indirectly, or otherwise, to third persons unless such third persons are individually identified by name herein and expressly described as intended beneficiaries of the terms of this Contract.

34. Compliance with Applicable Law

Contractor shall comply with all federal, state, and local laws applicable to the Work under this Contract, and all regulations and administrative rules established pursuant to those laws.

Contractor shall maintain in effect all licenses, permits and certifications required for the performance of the Work. Contractor shall notify EWEB immediately if any license, permit, or certification required for performance of this Contract ceases to be in effect for any reason.

35. Governing Law

The provisions of this Contract shall be construed in accordance with the laws of the State of Oregon and ordinances of Lane County, Oregon. Any legal action involving any question arising under this Contract must be brought in Lane County, Oregon. If the claim must be brought in a federal forum, then it shall be brought and conducted in the United States District Court for the District of Oregon.

REGULATORY COMPLIANCE

36. Severability

If any term or provision of this Contract is declared by a court of competent jurisdiction to be illegal or in conflict with any law, the validity of the remaining terms and provisions shall not be affected, and the rights

and obligations of the parties shall be construed and enforced as if the Contract did not contain the particular term or provision held invalid.

37. Waiver

Waiver of any default under this Contract by EWEB shall not be deemed to be a waiver of any subsequent default or a modification of the provisions of this Contract.

38. Uniform Commercial Code (UCC)

Except as otherwise provided herein, the Uniform Commercial Code (UCC), as adopted in Oregon shall apply to this Contract.

39. Taxes

EWEB is a tax-exempt municipal corporation.
TIN #93-6001483; Tax exempt #93-880393K.

40. Foreign Contractor

If the Contract includes services and the amount of those services exceeds \$10,000 and if Contractor is not domiciled in or registered to do business in the state of Oregon, Contractor shall promptly provide the Oregon Department of Revenue all information required by that Department relative to this Contract. EWEB may withhold final payment under this Contract until Contractor has met this requirement.

41. Cooperative Purchasing

Other public agencies may utilize the results of this solicitation in accordance with ORS 279A.215 and Rule 2-0210. If utilized, EWEB assumes no liability or responsibilities for the actions of the utilizing parties, or as may pertain to the resulting Contract established by and between the utilizing agency and the Contractor. The utilizing agency and the Contractor assume full responsibility for any and all agreements established between the parties.

CONTACT INFORMATION

42. Contractor Contacts

Contractor shall designate all key persons responsible for Contractor's Work under this Contract. Contractor shall provide EWEB the names, addresses and telephone numbers of such persons and shall keep this information current at all times. The primary representative shall be thoroughly familiar with the terms of the Contract and shall have the technical knowledge to perform the Work.

Account Representative: **Name, Cell Phone, Email**

Day to Day Contact (if different than above): **Name, Cell Phone, Email**

Accounts Receivable Contact: **Name, Phone, Email**

43. EWEB Contacts

Following are EWEB's contacts for this Contract:

Contract Administrator: Alex Nonte-Clark, 541-685-7983, alex.nonte-clark@eweb.org

Accounts Payable: accountspayable@eweb.org

Purchasing Contact: Kristin Kokkeler, 541-685-7107, kristin.kokkeler@eweb.org

44. Notices

Except as otherwise expressly provided in this Contract, any communications between the parties hereto or notices to be given hereunder shall be given in writing by personal delivery, email, U.S. Postal Service, or commercial delivery service to Contractor or EWEB at the address or email set forth on the signature page of this Contract, or to such other addresses or emails as either party may hereafter indicate pursuant to this

Section. Any communication or notice so addressed and mailed, other than email, shall be deemed to be given five (5) days after mailing. Any communication or notice delivered by email shall be deemed to be given within one (1) hour after being sent/transmitted. Any communication or notice by personal delivery shall be deemed to be given when actually delivered.

CONTRACT ACKNOWLEDGEMENTS AND EXECUTION

45. Contract Documents

This Contract consists of the following documents, hereby incorporated by reference, which are listed in descending order of precedence: this Contract less all attachments and exhibits, Attachment A - Schedule of Goods.

This Contract and the attached attachments and exhibits constitute the entire agreement between the parties. All understandings and agreements between the parties and representations by either party concerning this Contract are contained in this Contract. No waiver, consent, modification or change in the terms of this Contract shall bind either party unless in writing signed by both parties. Any written waiver, consent, modification or change shall be effective only in the specific instance and for the specific purpose given.

46. Assurances:

- The undersigned represents and warrants to EWEB that they have the power and authority to enter into and perform this Contract and that this Contract, when executed by EWEB, shall be a valid and binding obligation of Consultant enforceable in accordance with its terms.
- By signing this Contract, Contractor agrees that, in the event of a conflict, all the terms and conditions of this Contract supersedes all preprinted terms and conditions on any forms used by the Contractor.
- Contractor, by signing this Contract, represents and warrants that Contractor's performance under this Contract creates no potential or actual conflict of interest, including but not limited to conflicts of interest as defined in ORS 244.020. Contractor further warrants that no state or federal law or EWEB Rule prevents Contractor's lawful performance of the Contract. If Contractor is currently performing Work for EWEB or another governmental entity, Contractor's participation in other public contracts does not create a potential or actual conflict of interest in performance of this Contract.
- Contractor shall, at all times during the term of this Contract, be duly licensed to perform the Work, and if there is no licensing requirement for the profession or Work, be duly qualified and professionally competent.
- Contractor understands that the Owner is an Equal Employment Opportunity and Affirmative Action employer and requires Contractors and their sub-Contractors to follow EEO/AA practices in their performance of a Contract with EWEB.

47. CONTRACT EXECUTION

CONTRACTOR, BY EXECUTION OF THIS CONTRACT, HEREBY ACKNOWLEDGES THAT CONTRACTOR HAS READ THIS CONTRACT, UNDERSTANDS IT, AND AGREES TO BE BOUND BY ITS TERMS AND CONDITIONS.

CONTRACTOR:

Company Name

Company Address

Telephone Number

Fax Number

FEDERAL ID NUMBER

Email Address: _____

Title

Person Signing Contract (Please print or type Name)

Signature: _____

EXECUTION

EWEB:

Contract Administrator – Alex Nonte-Clark Date

Email Address: _____

Supervisor/Manager - Name Date

Purchasing Supervisor - Name Date of Execution



1. APPLICATION

- A. Metal enclosed, manually operated deadfront padmounted switchgear with load interrupting switches are installed outdoors on pads in EWEB's 12.47 kV grounded y/7.2 kV electric distribution system.

2. REFERENCE STANDARDS

- A. The padmounted switchgear shall be manufactured, tested and furnished according to the latest edition, revision or amendments to the applicable standards of ANSI, IEEE and NEMA, including IEEE C57.12.28 and IEEE C.37.74, except as modified herein.

3. PRODUCTS

A. General Requirements

- 1) The padmounted switchgear shall consist of a single self-supporting metal enclosure containing air break switches, fuses, and insulated busses with necessary accessory components all completely assembled, tested and operationally checked.
- 2) Different models of padmounted switchgear are presented in the standard detail included as a supplement to this specification. The padmounted switchgear model will be specified by EWEB's request for quotation or purchase order.
- 3) The dimensions of padmounted switchgear shall not exceed 75" in width and 73" in depth.
- 4) The unit is to be used on a solidly grounded wye system.

MATERIAL SPECIFICATION		
EUGENE WATER & ELECTRIC BOARD		
DEADFRONT PADMOUNTED SWITCHGEAR – 15KV	Apr 1, 2026	REV.
	ES5-5.1100	1
Page 1 of 12		

B. Ratings

- 1) The ratings of padmounted switchgear shall be:
 - a) kV, Nominal 14.4
 - b) kV, Maximum 17.0
 - c) kV, BIL 95.0
 - d) Main Bus Continuous, Amperes 600
 - e) Three-Pole Interrupter Switches:
 - Continuous, Amperes 600
 - f) Load Dropping, Amperes 600
 - g) Two-Time Duty Cycle Fault-Closing Amperes, RMS Asymmetrical 22,400
 - h) Fuses Maximum, Amperes 200E
 - i) Short-Circuit Ratings:
 - Amperes, RMS Symmetrical 12,500

C. Construction

- 1) Insulators
 - a) The interrupter-switch and fuse mounting insulators shall be of a cycloaliphatic epoxy resin system or porcelain.
- 2) Bus
 - a) Bus and interconnections shall consist of copper or aluminum bar.
 - b) Bus and interconnections shall withstand the stress associated with short circuit currents exceeding the rating of the switchgear.
 - c) Bolted aluminum-to-aluminum connections shall be made with two Belleville spring washers per bolt, one under the bolt head and one under the nut. Bolts shall be tightened to appropriate torque to assure good electrical connection.
 - d) All electrical contact surfaces shall have aluminum oxide film removed and be immediately coated with an oxide inhibitor and sealant before installation of the bus.
 - e) Tie bus, where furnished, shall consist of continuous, one piece sections of copper or aluminum bar. Flexible braid or cable shall not be used.

MATERIAL SPECIFICATION EUGENE WATER & ELECTRIC BOARD		
DEADFRONT PADMOUNTED SWITCHGEAR – 15KV	Apr 1, 2026	REV.
	ES5-5.1100	1
Page 2 of 12		

3) Grounding Provisions

- a) A ground connection pad shall be provided in each termination compartment.
- b) The ground connection pad shall be constructed of 1/4" thick galvanized or nickel plated steel and be welded to the enclosure and shall have a short-circuit rating equal to that of the switchgear and have a NEMA 2 hole pattern for ground connections.
- c) A copper rod having a short-circuit rating equal to that of the padmounted switchgear, shall be provided in each termination compartment. The rod shall extend across the full width of each compartment, readily accessible in an up-front location to allow grounding of cable concentric neutrals and accessories.

4) Bushing and Bushing Wells

- a) Bushing and bushing wells shall be of a cycloaliphatic epoxy resin system and conform to the latest revision of IEEE Standard 386.
- b) The bushing and bushing wells shall be mounted on the interior walls at a minimum height of 30" above the enclosure base.
- c) The semiconductive coating on bushings and bushing wells shall be solidly grounded to the enclosure.
- d) Switch terminals shall be equipped with 600-ampere-rated bushings and shall have removable threaded studs compatible with all 600-ampere elbow systems.
- e) Fuse terminals shall be equipped with 200-ampere-rated bushing wells with removable studs and factory installed 200 ampere load break bushing well inserts, Elastimold catalog #1601A4, or equal.

5) Termination Compartments

- a) All termination compartments shall be provided with one parking stand for each bushing or bushing well.

MATERIAL SPECIFICATION EUGENE WATER & ELECTRIC BOARD		
DEADFRONT PADMOUNTED SWITCHGEAR – 15KV	Apr 1, 2026 ES5-5.1100	REV. 1
Page 3 of 12		

b) Switch Termination Compartment

- i. Switch termination compartment shall be equipped with a viewing window to allow visual inspection of open gap between interrupter-switch blades when switch is in the open position.
- ii. Termination compartments for bushings rated 600 amperes continuous shall be of an adequate depth to accommodate two 600 ampere elbows mounted piggyback, encapsulated surge arresters or grounding elbows mounted on 600 ampere elbows having 200 ampere interface, or other similar accessory combinations without the need for an enclosure extension.

c) Fuse Termination Compartment

- i. Fuse termination compartment shall be equipped with a set of viewing windows to allow visual inspection of blown-fuse indicator on power fuses.
- ii. Provide a cable guide for each cable at the base of the enclosure to allow unobstructed rotation of fuse mounting panel. Cable guide shall be a minimum of 8” long from edge of enclosure to inside surface of cable guide.

6) Interrupter Switches

- a) Interrupter switches shall be operated by means of an externally accessible switch-operating hub. The switch-operating hub shall be located within a recessed pocket mounted on the side of the padmounted enclosure and shall accommodate a deep socket wrench or a shallow-socket wrench with extension. The switch-operating hub pocket shall include a padlockable access cover that shall incorporate a hood to protect the padlock shackle from tampering. Stops shall be provided on the switch-operating hub to prevent overtravel and guard against damage to the interrupter switch quick-make quick-break mechanism. Labels to indicate switch position shall be provided in the switch-operating hub pocket.
- b) Each interrupter switch shall be provided with a switch-operating handle which shall be secured to the inside of the switch

MATERIAL SPECIFICATION EUGENE WATER & ELECTRIC BOARD			
DEADFRONT PADMOUNTED SWITCHGEAR – 15KV	Apr 1, 2026	ES5-5.1100	REV. 1
Page 4 of 12			

operating hub pocket and stored behind the closed switch-operating-hub access door.

- c) Interrupter switches shall utilize a quick-make quick-break mechanism installed by the switch manufacturer. It shall swiftly and positively open and close the interrupter switch independent of the switch-operating hub speed.
- d) Each interrupter switch shall be completely assembled and adjusted by the switch manufacturer on a rigid mounting frame. The frame shall be of heavy gauge steel construction.
- e) Interrupter switch contacts shall provide constant high contact pressure.
- f) Interrupter switches shall be provided with a single blade per phase for circuit closing, including fault closing, continuous current carrying, and circuit interrupting. Spring loaded auxiliary blades shall not be permitted.
- g) Circuit interruption shall be accomplished by use of an interrupter which is positively and inherently sequenced with the blade position. It shall not be possible for the blade and interrupter to get out of sequence. Circuit interruption shall take place completely within interrupter, with no external arc or flame.

7) Power Fuse Mounting

- a) Fuse mountings shall accept S & C type SML-20 fuse end fittings and S & C type SMU-20 fuses. Fuse end fittings and fuses are not to be supplied with switch.
- b) Fuse mounting shall be enclosed in an inner steel compartment and shall be provided with 200 ampere-rated bushing wells for elbow connection.
- c) Each fuse mounting shall be an integral part of fuse handling mechanism that does not allow access to the fuse until the elbow for that fuse has been disconnected.
- d) The opening into the component compartment shall be covered by a panel in both the open and closed position to prevent inadvertent access to high voltage.

MATERIAL SPECIFICATION EUGENE WATER & ELECTRIC BOARD		
DEADFRONT PADMOUNTED SWITCHGEAR – 15KV	Apr 1, 2026	REV.
	ES5-5.1100	1
Page 5 of 12		

- e) Provide fuse retainer bail to secure pull-ring end of fuse assembly to fuse mounting clip.

8) Enclosure

- a) The padmounted enclosure shall be of unitized construction to maximize strength, minimize weight, and inhibit corrosion.
- b) The enclosure and doors shall be minimum 11-gauge hot rolled, pickled and oiled steel sheet.
- c) The enclosure roof shall be diamond shape or have a slope to let the water run off.
- d) All structural joints and butt joints shall be welded, and the external seams shall be ground flush and smooth. A welding process shall be employed that eliminates alkaline residues and minimizes distortion and spatter.
- e) All enclosure corners shall be rounded and finished.
- f) The enclosure shall be provided with tamper-proof ventilation louvers with 300 series stainless steel screens, one near the top and one near the bottom of exterior wall of each termination compartment, to allow circulation of the air.
- g) The enclosure shall guard against unauthorized or inadvertent entry. Enclosure construction shall not utilize any externally accessible hardware.
- h) The base shall consist of continuous 90-degree flanges, turned inward and welded at the corners, for bolting to the concrete pad.
- i) The door openings shall have 90-degree flanges, facing outward, that shall provide strength and rigidity as well as deep overlapping between doors and door openings to guard against water entry.
- j) Gasketing between the roof and the enclosure shall guard against entry of water and airborne contaminants and shall discourage tampering or insertion of foreign objects.

MATERIAL SPECIFICATION			
EUGENE WATER & ELECTRIC BOARD			
	Apr 1, 2026	REV.	
DEADFRONT PADMOUNTED SWITCHGEAR – 15KV	ES5-5.1100	1	
Page 6 of 12			

- k) A heavy coat of insulating "no-drip" compound shall be applied to the inside surface of the roof to reduce condensation of moisture thereon.
- l) An internal steel-enclosed compartment shall encase the interrupter switches and fuses for electrical insulation and protection from contamination. The compartment shall have a galvanized steel floor to keep out foliage and animals. The floor shall have an additional undercoating to minimize corrosion. The floor shall have screened drain vents to allow drainage if the enclosure is flooded. The top of this compartment shall be gasketed to provide sealing with the enclosure roof.
- m) Insulating interphase and end barriers shall be provided in each switch and fuse compartment. These barriers shall be constructed of fiberglass-reinforced polyester.
- n) Lifting tabs shall be removable and sockets for the lifting tab bolts shall be blind-tapped. A protective material shall be placed between the lifting tabs and the enclosure to prevent the tabs from scratching the enclosure finish. This material shall be non-hygroscopic to prevent moisture from being absorbed.
- o) Doors shall be hinged at the sides to swing open with minimum effort. Each door shall have a door holder which cannot swing inside the enclosure and shall be hidden from the view when the door is closed.
- p) Doors shall have a minimum of three stainless steel hinges and hinge pins. The hinge pins shall be secured in place to guard against tampering.
- q) In consideration of controlled access and tamper resistance, each door (or set of double doors) shall be equipped with an automatic three-point latching mechanism. The latching mechanism shall be spring loaded, and shall latch automatically when the door is closed. All latch points shall latch at the same time to preclude partial latching.
- r) A pentahead socket wrench or tool shall be required to actuate the mechanism to unlatch the door and in the same motion, recharge the spring for the next closing operation.

MATERIAL SPECIFICATION			
EUGENE WATER & ELECTRIC BOARD			
	Apr 1, 2026	REV.	
DEADFRONT PADMOUNTED SWITCHGEAR – 15KV	ES5-5.1100	1	
Page 7 of 12			

- s) Doors providing access to power fuses shall have provisions to store spare fuse units or refill units.

9) Finish

- a) The padmounted switchgear enclosures shall be coated in accordance with manufacturer's practice, to provide a high quality finish.
- b) The manufacturer's coating system shall be tested in accordance with the latest revision of IEEE C.57.12.28 and shall meet or exceed the indicated performance criteria. The tests results shall be made available to EWEB upon request.
- c) Unless otherwise specified, the finish coat shall be manufacturer's standard dark green color.

10) Labeling

- a) NEMA approved warning signs shall be placed on all external doors and inside of each door. All signs shall be applied and located in accordance with latest NEMA standards.
- b) A nameplate indicating the manufacturer's name, catalog number, and model number shall be permanently applied to the inside of at least one door on each padmounted switchgear. Also, the inside of each door shall be provided with a ratings label indicating the following: voltage ratings; main bus continuous rating; short-circuit ratings (amperes, RMS symmetrical and MVA three-phase symmetrical at rated nominal voltage); the type of fuse and its maximum ampere ratings; the interrupter switch ratings, including duty-cycle fault-closing capability and amperes, short-time, RMS (momentary, asymmetrical and one-second, symmetrical).
- c) A three-line connection diagram showing interrupter switches, fuses and bus along with the manufacturer's model number shall be provided on the inside of the front and rear doors, and on the inside of each switch-operating-hub access cover.

4. TESTS

MATERIAL SPECIFICATION			
EUGENE WATER & ELECTRIC BOARD			
	Apr 1, 2026	REV.	
DEADFRONT PADMOUNTED SWITCHGEAR – 15KV	ES5-5.1100	1	
Page 8 of 12			

- A. Factory Tests: Padmounted switchgear shall be tested according to the latest revision of IEEE C.37.74. The results of testing shall be available to EWEB upon request.

5. WARRANTY

- A. Provide a warranty period of eighteen (18) months minimum after the date of acceptance.
- B. Unless otherwise stated, all equipment shall be free and clear of any lien or encumbrances and shall be new and the current model and shall carry full manufacturer warranties.
- C. Vendor warrants to EWEB that any goods/equipment furnished will operate and function in the manner represented by Vendor and will achieve the performance stated in the material specification when operating within the design conditions described therein.
- D. Vendor warrants the goods/equipment furnished is free from defects in material and workmanship, and agrees to repair or replace any unit that is unsuitable for operating or fails in operation during normal and proper use, including all parts and labor at no cost to EWEB.

6. PACKAGING AND DELIVERY

- A. The vendor shall protect the padmounted switchgear and any exposed parts during transit. Any damage in transit is the vendor's responsibility.

7. SUBMITTALS

- A. Submit the information required in Exhibit A.
- B. Provide one (1) set of drawings and instruction books before shipment of the padmounted switchgear. One complete set of drawings and instruction books shall accompany the padmounted switchgear. All instruction books shall be provided in PDF file format and all drawings shall be provided in the latest version of AutoCAD®, or PDF file format.

8. EWEB STORES INFORMATION

MATERIAL SPECIFICATION			
EUGENE WATER & ELECTRIC BOARD			
	Apr 1, 2026	REV.	
DEADFRONT PADMOUNTED SWITCHGEAR – 15KV	ES5-5.1100	1	
Page 9 of 12			

A. This specification shall be used to purchase the material with the following stock codes:

492-0001800 Model 9. Deadfront Padmount Switch, 600 Amp, Two 3 Pole Disconnects, Two 200 Amp 3 Pole Fuse Positions.

492-0001802 Model 11. Deadfront Padmount Switch 600 Amp, Three 3 Pole Disconnects, One 200 Amp 3 Pole Fuse Position.

492-0001803 Model 5. Deadfront Padmount Switch 600 Amp, One 3 Pole Disconnect. One 200 Amp 3 Pole Fuse Position.

MATERIAL SPECIFICATION
EUGENE WATER & ELECTRIC BOARD

	Apr 1, 2026	REV.
DEADFRONT PADMOUNTED SWITCHGEAR – 15KV	ES5-5.1100	1

Date: _____

EXHIBIT A

**SPECIFIC INFORMATION REQUIRED WITH BID
DEADFRONT PADMOUNTED SWITCHGEAR
(Submit Separate Sheets for Each Bid Item)**

Manufacturer's Name: _____

Distributor's Name: _____

1. PADMOUNTED SWITCHGEAR MODEL _____

2. VOLTAGE:
a. KV, Nominal _____
b. KV, Maximum design _____
c. KV, BIL _____

3. MAIN BUS CONTINUOUS AMPERES _____

4. INTERRUPTER SWITCHES:
a. Continuous Amperes _____
b. Load Dropping Amperes _____
c. Two-Time Duty Cycle, Fault Closing _____
d. RMS Asymmetrical Amperes _____

5. FUSES, MAXIMUM AMPERES _____

6. SHORT CIRCUIT RATINGS:
a. RMS Symmetrical Amperes _____

Submit a drawing of the switch showing the dimensions, vent locations and switch and fuse configuration in accordance with the requirements of the bid documents.

MATERIAL SPECIFICATION EUGENE WATER & ELECTRIC BOARD		
DEADFRONT PADMOUNTED SWITCHGEAR – 15KV	Apr 1, 2026	REV.
	ES5-5.1100	1
Page 11 of 12		

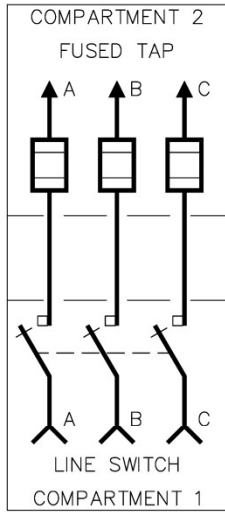

MODEL 5
EWEB STOCK CODE 492-0001803

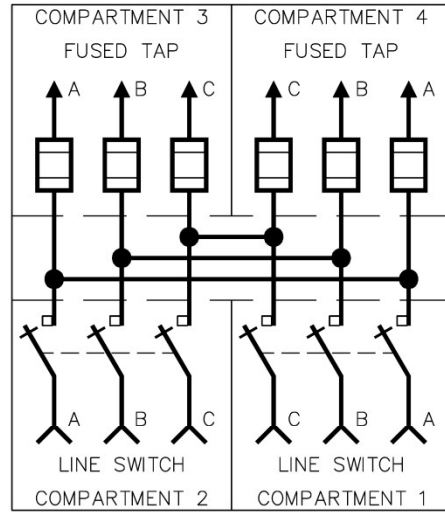

MODEL 9
EWEB STOCK CODE 492-0001800

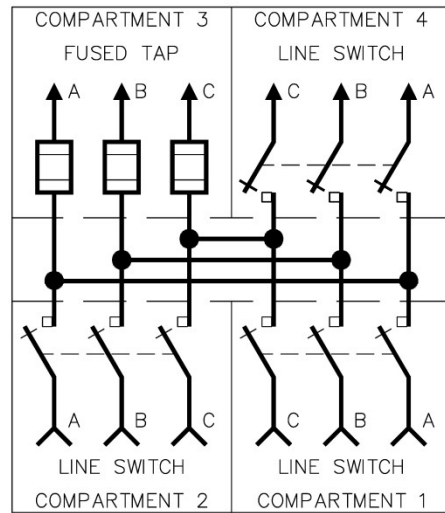

MODEL 11
EWEB STOCK CODE 492-0001802

DEADFRONT PADMOUNTED SWITCHGEAR CONNECTION DIAGRAM
STANDARD DETAIL ES5-5.1100.01

MATERIAL SPECIFICATION EUGENE WATER & ELECTRIC BOARD		
DEADFRONT PADMOUNTED SWITCHGEAR – 15KV	Apr 1, 2026	REV.
	ES5-5.1100	1
Page 12 of 12		